

磷酸铁锂电池组规格书

LiFePO4 Battery Specification

Model: TB12200F-SC-S110A

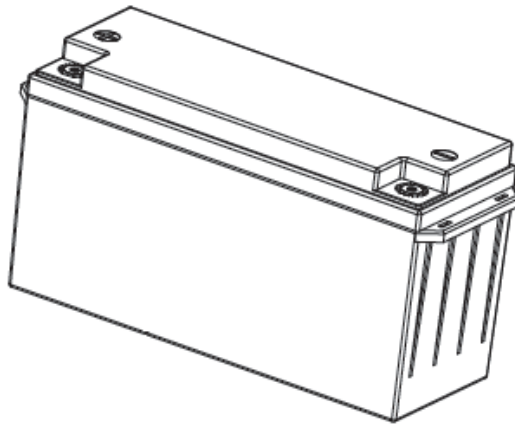

深圳市拓邦锂电池有限公司 / SHENZHEN TOPBAND LITHIUM BATTERY CO.,LTD

地址: 深圳市 宝安区 石岩镇 梨园工业区 拓邦工业园, 邮编 518108

Address: Topband Industrial Park, Liyuan Industrial Zone, Shiyan, Bao'an, Shenzhen, China, 518108.

网址/ Web: : www.topband.com.cn

编辑 Registered	吴小平 Tom	客户名称 Customer	
审核 Checked	邓兆威 Dengzhaowei	客户型号 Customer Model	
批准 Approved	郑云华 Zhengyunhua	客户回签 / Customer Reback:	
发布日期 Issued Date	2018-5-2		
发布版本 Issued Version	V00		
文件编号 Document Number	XNY-01-43		

修订记录 Modified Record

版本 Revision	修订日期 Date	修订内容 Modified Content	负责人 Principle
V00	2018-5-2	设计 Design	吴小平 Tom

1. 概述 / General Information

本规格书适合于深圳市拓邦锂电池有限公司研制的 **TB12200F-SC-S110A** 电池组，描述了其外型尺寸、特性、技术要求及使用注意事项。

This specification defines the performance of rechargeable LiFePO4 battery pack **TB12200F-SC-S110A** manufactured by SHENZHEN TOPBAND LITHIUM BATTERY CO.,LTD describes the type, performance, technical characteristics, warning and caution of the battery pack.

2. 电池技术规格 / Battery Specification (@ 25±5℃)

序号 NO	项目 Items		特性/ Characteristics
2.1	额定容量 Normal capacity		200Ah
2.2	额定能量 Nominal energy		2.56KWh
2.3	标称电压 Nominal voltage		12.8V (LFP-4S)
2.4	内阻 Internal resistance		≤20mΩ @1kHz AC
2.5	标准充电电压 Normal charge voltage		14.6±0.2V
2.6	浮充充电电压 Float charge voltage(for Standby use)		13.8±0.2V
2.7	最大持续充电电流 Allowed MAX charge current		200A
2.8	推荐充电电流 Recommended charge current		≤40A
2.9	最大持续放电电流 Allowed MAX discharge current		200A
2.10	放电终止电压 End of discharge voltage		10.0V
2.11	尺寸 Dimension		长 Length 485±2 mm
			宽 Width 170±2 mm
			高 Height 241±2 mm
2.12	重量(不含配件) Weight (No accessories)		约 About: 24.5Kg
2.13	工作温度 Operation temperature	充电 Charge	0~45℃
		放电 Discharge	-20~60℃
2.14	自放电率 Self-discharge rate	剩余容量 Residual capacity	≤3%/Month(月); ≤15%/ year (年)
		可恢复容量 Recover capacity	≤1.5%/Month(月); ≤8%/ year (年)
2.15	储存环境 Storage environment	≤1month(月)	小于1个月: -20~+60℃、5~75%RH
		≥3month(月)	小于3个月: -10~+45℃、5~75%RH
		推荐环境 Recommend environment	15~35℃、5~75%RH
2.16	串联应用 Series connection application	支持串联 Support series connection	

3.电气性能及测试条件 Electrical Characteristics & Test Condition

测试条件 Testing Conditions: Ambient Temperature: 25±5℃; Humidity:45%~75%.

标准充电: 在 CC(0.33C)/CV(14.6V)模式下充电至过充保护或电流减小至 0.05C, 然后静置 1h。

Normal charge: Charge battery under CC(0.33C)/CV(14.6V) mode until over charge protection or the charge current reduce to 0.05C, and then rest for 1h.

序号 NO	项目 Items	标准 Criterion	测试方法 Condition	
3.1	额定容量 Normal Capacity	200Ah	电池经标准充电后, 以 0.33C 电流放电至截止电压。 After Normal charge, discharge @0.33C current to the end of discharge voltage.	
3.2	初始内阻 Internal Impedance	≤20m Ω	在 50%SOC 条件下用 1kHz AC 的交流内阻测试仪。 @50% SOC @1kHz AC internal resistance test instrument.	
3.3	短路保护 Short circuit protection	短路后自动断开负载 Auto cutoff load when short circuit	用 0.1Ω 的电阻短接电池的输出正、负极 Connect the positive and negative of this battery pack through a lead with 0.1Ω resistance.	
3.4	循环寿命 Cycle life @DOD100%	≥2000 次循环 ≥2000 cycles	电池标准充电后以 0.33C 电流放电至截止电压, 静置 1h; 重复上述步骤直至放电容量小于初始容量的 80%。 After Normal charge, discharge @0.33C current to the end of discharge voltage. Repeat above process until discharge capacity reduce to 80% of initial value.	
3.5	放电温度特性 @0.33C Discharge temperature characteristic @0.33C	-20℃ (6h)	≥70%	特定温度放电容量 25℃放电容量 的比值符合左表所列标准 $\frac{\text{Capacity @ specified temperature}}{\text{Capacity @ 25}^\circ\text{C}}$ the percentage accord with criterion
		0℃ (6h)	≥80%	
		25℃ (4h)	≥100%	
		55℃ (4h)	≥95%	
3.6	容量保存率 Capacity retention rate	恢复容量≥96% remain capacity ≥96%	电池经标准充电后, 在 25±5℃环境下开路搁置 28d 后, 以 0.33C 恒流放电至截止电压, 放电容量应符合试验要求。 After normal charge, store the battery @25±5℃ for 28days, then discharge capacity @0.33C, the retention capacity accord with criterion.	

4.保护电路规格参数 Circuit Protection

本电池内部包含锂电保护板，能实时监控电池运行状态，必要时提供过充、过放、过流、过温等保护，必要时切断动力电池的输入输出进行保护。

The batteries are supplied with a LiFePO4 Battery Management System (BMS) that can monitor and optimized each single prismatic cell during charge & discharge, to protect the battery pack overcharge, over discharge, short circuit. Overall, the BMS helps to ensure safe and accurate running.

序号 No	项目 Item	内容 Content	检验标准 Criterion
4.1	过充 Over charge	单串过充保护电压 Over-charge protection for each cell	3.75±0.05V
		单串过充恢复电压 Over-charge release for each cell	3.60±0.05V
		过充保护恢复方法 Over-charge release method	低于恢复电压后 Under the release voltage
4.2	过放 Over discharge	单串过放保护电压 Over-discharge protection each cell	2.50±0.05V
		单串过放恢复电压 Over-discharge release for each cell	2.80±0.05V
		过放保护恢复方法 Over-discharge release method	充电恢复 Charging
4.3	过流 Over current	充电过流保护值 Charge over current protection	250±10A, delay time 30s±5s
		充电过流保护解除方法 Charge over current release	放电(>1A)解除或者 1min 后自动解除 Discharge or auto release after 1min
		放电过流保护值 Discharge over current protection	255A±5A, delay time 30s±5s
		放电过流保护解除方法 Discharge over current release	充电(>1A)解除或者 1min 后自动解除 Charge or auto release after 1min
		短路保护 Short circuit protection	有 Available
4.4	温度 Temperat ure	电池充电高温保护 Charge over temperature protection	65±5℃ 保护, 50±5℃ 恢复 Protect@65±5℃; Release@50±5℃;
		电池充电低温保护 Charge under temperature protection	-0±3℃ 保护, 5±3℃ 恢复 Protect@-5±5℃; Release@0±5℃
		电池放电高温保护 Discharge over temperature protection	65±5℃ 保护, 50±5℃ 恢复 Protect@65±5℃; Release@50±5℃;
		电池放电低温保护 Discharge under temperature protection	-20±5℃ 保护, -15±5℃ 恢复 Protect@-20±5℃; Release@-15±5℃;

5. 结构尺寸 / Structure Dimension

5.1 电池尺寸 / Battery Dimension

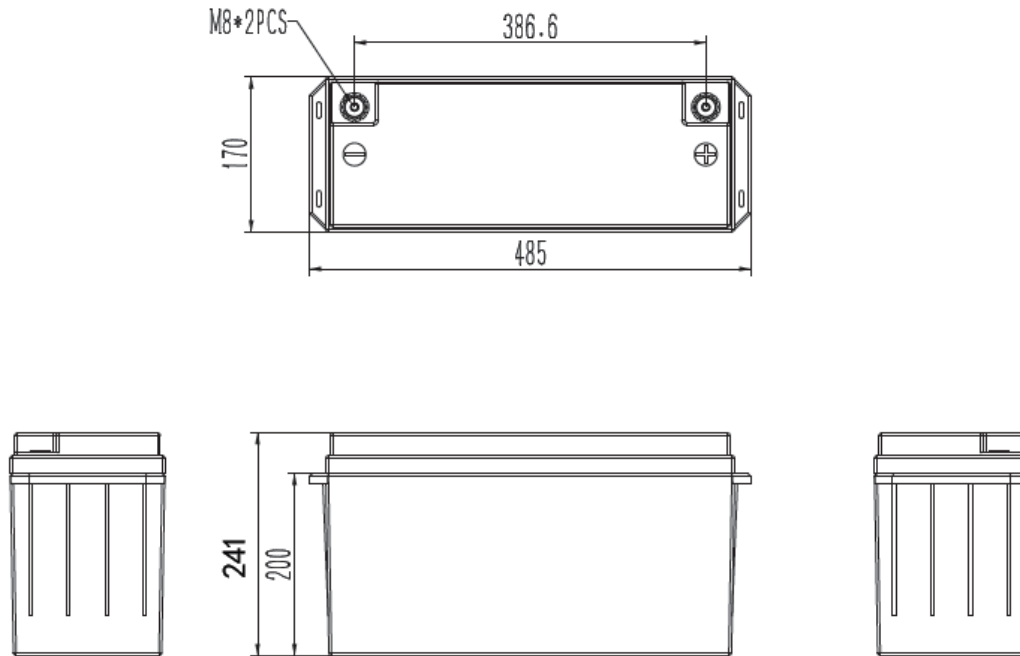

6 运输、存储注意 / Transport & Store

长期储存时，按规格书规定的方式每 6 个月需充放电循环一次。

The battery need to be charged every 6 months if out of use

运输过程装卸电池时请注意不要摔落，请勿超过 6 层堆积、翻转放置，保证正面朝上。

No fall down, no pile up over 6 layers, and keep face up.

7 警示及注意事项 / Warning & Tips

使用电池前请仔细阅读规格书和电池箱表面的警示标志。不当的使用电池可能会引起电池过热损坏，对于未按规格书操作造成的任何意外事故，深圳市拓邦锂电池有限公司不负担任何责任，为了使电池安全的使用及处理请在使用前认真的阅读操作说明：

Please read and follow the handling instructions before use. Improper use may cause heat, fire, rupture, damage or capacity deterioration of the battery. SHENZHEN TOPBAND LITHIUM BATTERY CO.,LTD Describes is not responsible for any accidents caused by the usage without following our handling instructions.

警告 Warning

- * 电池请远离热源、高压场所、并避免长时间的日光暴晒；
- * Battery must be far away from heat source, high voltage, and no exposed in sunshine for long time.

- * 不能将电池投入水或火中;
 - * Never throw the battery into water or fire;
 - * 不要接反电池的正负极;
 - * Never reverse two electrodes when use the battery;
 - * 不要用金属短接电池正负极;
 - * Never connect the positive and negative of battery with metal;
 - * 避免过分的物理震动和冲击电池，不要撞击、摔落、踩踏电池;
 - * Never knock, throw or trample the battery;
 - * 未经厂家许可和指导，严禁私自拆卸或组装电池;
 - * Never disassemble the battery without manufacturer's permission and guidance.
 - * 不能将其它不同厂家，类型，型号的电池混合使用;
- Never use mixed with other type of battery;

注意 Tips

- * 请不要高温环境下使用或储存，否则会引起电池发热、起火或使用寿命降低;
- * Keep the battery against high temperature. Otherwise it will cause battery heat, get into fire or lose some function and reduce the life.
- * 电池用完电后，请及时(15天内)充电;
- * When battery run out of power, please charge your battery timely (≤ 15 day).
- * 请使用配套或者推荐的专业锂电池充电器;
- * Please use the matched or suggested charger for this battery.
- * 电池有异味、变色、噪音、漏液、严重变形等异常情形时，请停止使用;
- * If battery emit peculiar smell, heating, distortion or appear any abnormality, please stop using.
- * 电解液泄露溅入皮肤、眼睛时，用清水冲洗并立即找医生诊治;
- * If the battery leaks and get into the eyes or skin, do not wipe, instead, rinse it with clean water and see doctor immediately.
- * 请将电池放置在宠物和儿童接触不到的位置，禁止小孩接触电池.
- * Please far away from children or pets.